



K+ SERIES: UFWWK-2

Two Hole Waterless Wok Table

Project: _____ Item: _____



UFWWK-2

Standard Features:

- AISI Grade Stainless Steel
- Heavy duty complete stainless steel frame
- Long skirt cast iron unflued ring - 340mm Diameter
- Waterless feature eliminates the need for deck cooling
- One-piece machine pressed top deck - 1.5mm Thick
- Manually operated laundry arm and spindle
- Heavy duty stainless steel lever action gas control
- Flame Failure & Pilot - Included as standard
- Front waste gutter allows for greater ease in cleaning
- Waste shovel included
- Front access to all components makes service easy

Options:

- Natural or LPG Gas
- 24 Jet Mongolian Chimney Burner (CB)
- 18 Jet Duckbill Burner (DB)

Specifications:

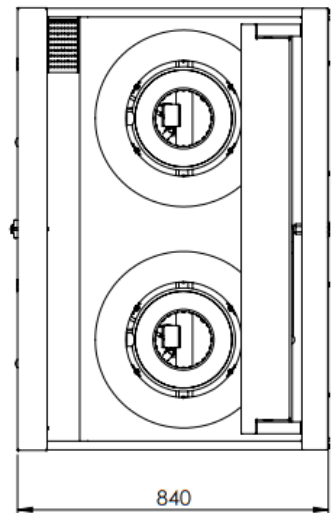
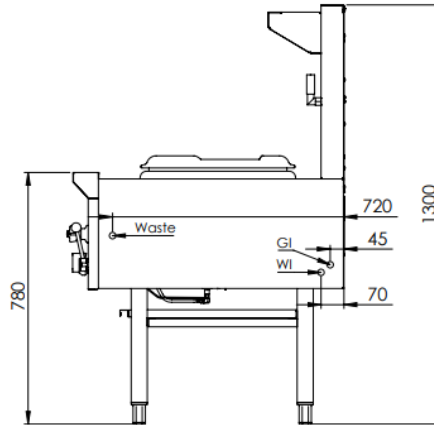
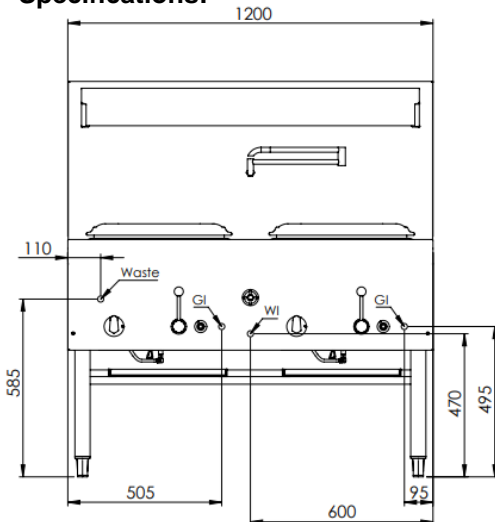

MODEL	LENGTH (mm)	DEPTH (mm)	HEIGHT (mm)	NET WEIGHT (kg)	GAS CONSUMPTION (Mj/h)			
					NG - CB	NG - DB	LPG - CB	LPG - DB
UFWWK-2	1200	840	1300	-	210	220	150	180

Connections:

GAS (GI) (BSP)	WATER (WI)	WASTE (BSP)	SUPPLY PRESSURE (kPa)	
			NG	LPG
3/4" (M)	1/2" (Copper)	2" (M)	1.0	2.6

- Gas regulator is included within the unit
- **Must** be installed by an authorised installer in accordance to **AS/NZS5601 refer to current version**

Due to ongoing Product Development, Product Improvement and Research, B+S Commercial Kitchens reserves the right to alter specification without notice.

Approval Number: GMK 10696



B+S Commercial Kitchens
57 Plateau Road Reservoir VIC 3073 Australia | +61 3 9469 4754
info@bscommercialkitchens.com | www.bscommercialkitchens.com

