

POT WASHERS

IM65

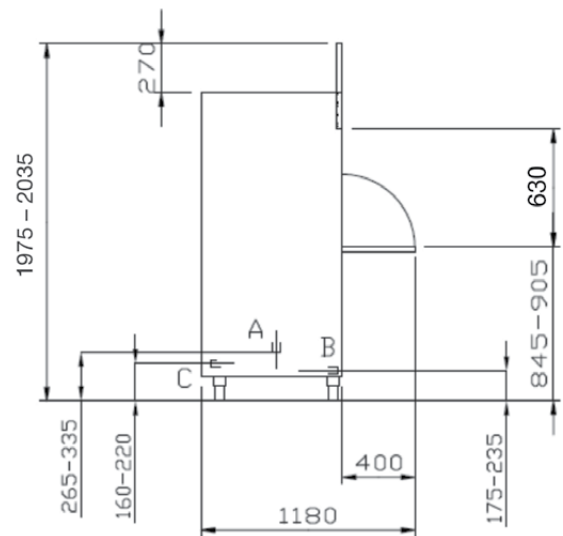
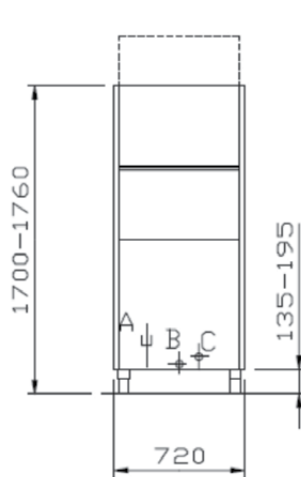

The IM65 commercial potwasher is designed to be ergonomically pleasing yet able to take care of the larger items found inside a kitchen. With a 650mm opening, it is ready to take on anything you are willing to throw at it.

FEATURES

- **Warranty** – 3 years on the control board, 1 year parts and labour on the remainder of the machine
- Energy Saving mode
- Automatic Detergent & Rinse Aid
- Self-Diagnostic system
- 2, 4, 6 & 12 minute cycles
- Low water consumption 4L per rack
- Quick ready function
- Double skinned door

INCLUSIONS

- 1 x Generic steel basket 550mm x 610mm
- 1 x Drain hose
- 1 x Water connection hose
- 1 X Operating manual

TECHNICAL DATA

Height

Cabinet	1565 mm
Cabinet inc. legs	1700-1760 mm
With hood extended	1975-2035 mm
Usable Wash	630 mm

Width

Cabinet	720 mm
---------	--------

Depth

Cabinet	780 mm
With door open	1180 mm

Capacities

Loads/Hour	up to 30*
Water per Cycle	4L
Wash Pump	1400W
Rinse Pump	200W
Wash Tank Litres	37
Boiler Litres	7
Element (wash)	3000W
Element (rinse)	6000W
Detergent Injection	yes
Rinse Aid Injection	yes

Temperatures

Wash Degrees C	60 °C
Rinse Degrees C	82 °C

Plumbing

Drain	Gravity
Water	¾" BSP (hot)

Electrical

Volts/Hz/Phase	400V/50Hz/3+N
Amps	16Amps/Ph

* Subject to incoming water temperature

