

CF0200ATCG | Angled Glass Top 176L Chest Freezer

Chest Freezers

CF0200ATCG

**ANGLED GLASS
TOP 176L CHEST
FREEZER**



CF0200ATCG | Angled Glass Top 176L Chest Freezer

Chest Freezers

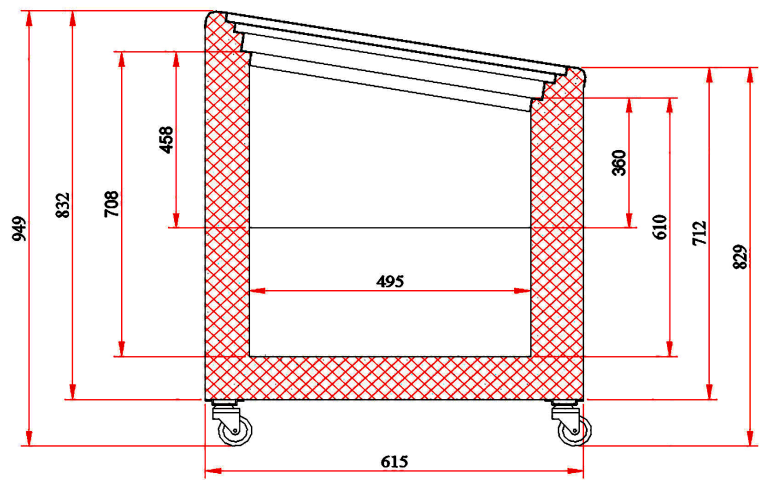
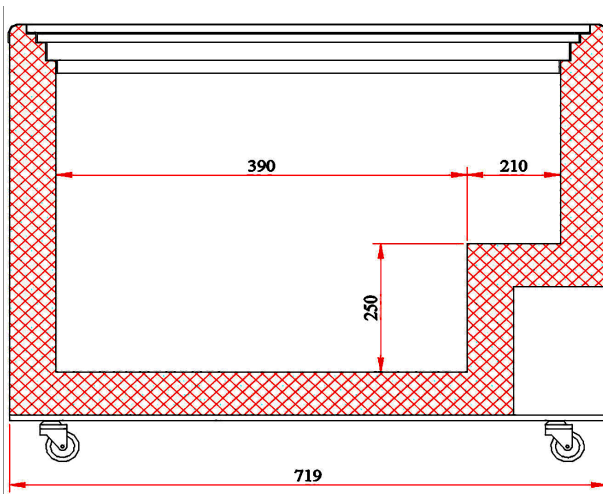

SPECIFICATIONS	Part Number	3735301	Internal Light	No
	Capacity	176L	No. of Lids	2
	Temperature range	-22 to -12°C	Lid Type	Slide - Glass
	Max. Ambient Temp	35°C	Lid Shape	Curved
	Refrigeration Capacity	190W	Lid Lock	Yes
	Energy Consumption	2.7kWh/24h	Temp. Controller	Digital
	Current	1.5A	Castors	Yes
	Gross Weight	57kg	No. Baskets Included	2
	Packaged Dimensions	740 x 680 x 980 mm	Colour	White
	Air-Circulation	Static	Warranty	2 Years, Parts & Labour
	Refrigerant	R404a	Warranty Service	Bromic Extra Care
	Plug Supplied	Yes, 1 x 10A		
	Plug Location	2m long, bottom right rear		

DIMENSIONS		External (mm)	Internal (mm)
	Width	719	600
	Depth	615	495
	Height	949	708

All information is correct at the time of publication. BROMIC PTY Ltd reserve the right to alter specifications without notice.