



PRODUCT CODE:

T-3M53007-C

The 3monkeez® range of tapware is perfectly suited for commercial kitchens, schools, canteens, bars, cafés, food processing facilities or any other commercial setting. The range includes Pre-Rinse Units, Mixers, Hot Wash Reels, Sensor Taps, Bubblers, Pillar, Bib Taps and more.

FEATURES & BENEFITS:

- Stainless steel construction
- Dual hob tap body includes inlet hoses - 1/2 turn rising spindles
- Self closing high water efficiency with a 6 star 4LPM VARIABLE trigger valve
- Stay open clip for prolonged use
- Fully assembled and bench tested
- 24 month warranty

CLEANJET®
STAINLESS STEEL



Details accurate at time of print. Whilst all care has been taken in compiling this information, designs & dimensions shown are indicative only and should not be relied upon without prior approval.

Top

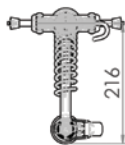

Working pressure range
150 – 1000kPa
Maximum hot water
temperature – 80°C

Front

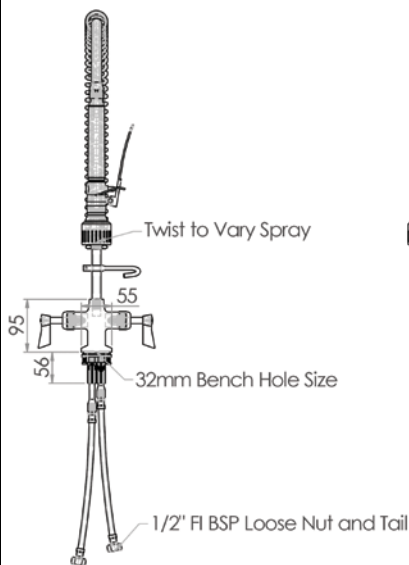

Side

